

# PHOTOVOLTAIC MODULE INSTALLATION INSTRUCTIONS

## 1. INTRODUCTION

- BEFORE INSTALLATION, OPERATION, AND MAINTENANCE, BE SURE TO READ THESE INSTRUCTIONS AND USE THE PV MODULE SAFELY.
- ALL APPLICABLE LOCAL CODES AND THE NATIONAL ELECTRICAL CODE SHOULD BE FOLLOWED.
- FAILURE TO OBSERVE THE FOLLOWING INSTRUCTIONS MAY RESULT IN DEATH OR PERSONAL INJURY AND PROPERTY DAMAGE.

### ⚠ WARNING

#### 1. GENERAL USE

- DO NOT use the PV module where failure could result in death, personal injury or damage to property.
- Make certain that PV module conforms to the specifications for the total system.







#### 2. GENERAL HANDLING

- Handle the PV module with care.
- DO NOT disassemble the PV module.
- DO NOT alter or remove any component.
- DO NOT bend the PV module.
- DO NOT stand or step on a module to avoid personal injury and the damage to a module.
- DO NOT impact on front or rear surface of the PV module. Rear surface may be damaged by sharp objects.
- DO NOT throw and drop the PV module.
- DO NOT touch live parts of wires, cables, connectors, or junction boxes. Be sure the circuit breaker is off if it's applicable. Always use appropriate safety equipment (insulated tools, insulating gloves, etc.).
- DO NOT use the cable and/or connectors as a handle.

#### 3. INSTALLATION

- Installers should be qualified personnel who are experienced with electrical work and the installation of PV systems.
- DO NOT use damaged PV modules. A damaged PV module may cause a fire and/or an electrical shock with personal injury or even death.
- DO NOT expose the PV module to artificially concentrated sunlight.
- Cover the front surface of the PV module with an opaque cloth or other material when installing and repairing. The PV module exposed to sunlight generates high voltage and current. Contact with the module output wiring may cause a fire or an electrical shock.
- Fasten the PV modules to the mounting framework firmly so that the modules will not be affected by wind and snow loads. The framework should meet relevant building standards.
- DO NOT block frame drain holes at each corner of module.
- Ground securely the PV modules and the mounting framework.
- Install the PV modules securely and properly to avoid accidents with personal injury or even death and damage to property by accumulated snow.
- Connect a circuit breaker or some equipment to detect the leakage current and then break the circuit.

Applicable models are shown as the following symbols.

Symbol	Model name
	PV-TD ***MF5
	PV-AD ***MF5
	PV-UD ***MF5
	PV-TE ***MF5N
	PV-AE ***MF5N
	PV-UE ***MF5N

\*\*\* stands for rating output power.

## 1-1. STRUCTURE

50-cell type

**TD** **AD** **UD**

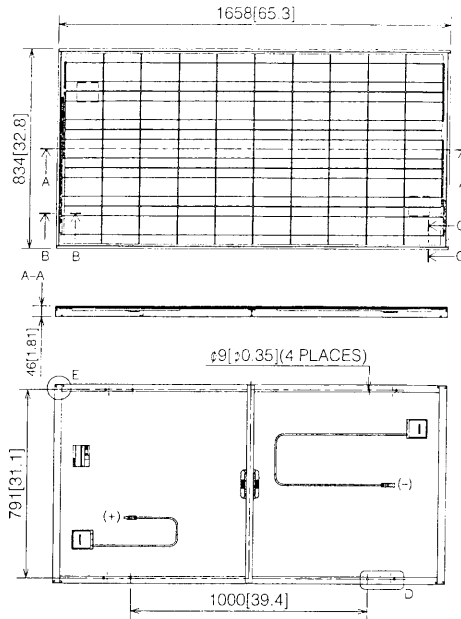

\* This figure represents TD type.

36-cell type

**TE** **AE** **UE**

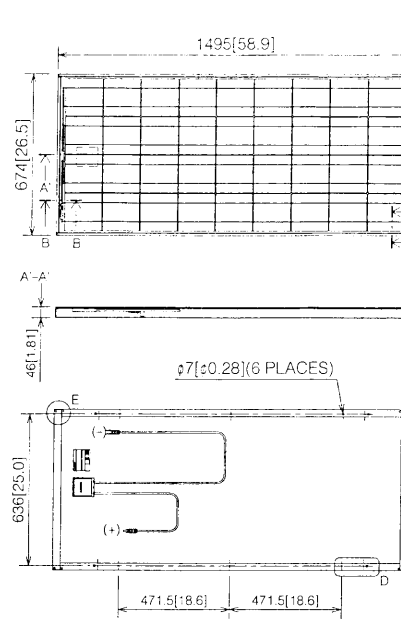

\* This figure represents TE type.

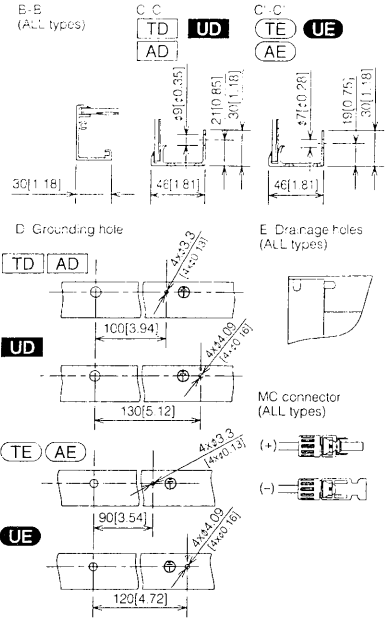

Unit:mm[inch]

## 1-2. MULTIPLYING FACTOR

Under normal conditions, the PV module is likely to experience conditions that produce more current and/or voltage than reported under Standard Test Conditions. Accordingly, the values of  $I_{sc}$  and  $V_{oc}$  marked on this module should be multiplied by a factor of 1.25 when determining component voltage ratings, conductor capacities (cross sectional area), fuse sizes, and size of controls connected to the PV output. Customers in US should refer to Section 690-8 of the National Electrical Code for an additional multiplying factor of 125 percent (80 percent derating), which may be applicable. Customers in other location should refer to the codes relevant to the location of installation for further guidance.

## 2.INSTALLATION

Refer to Local Code (US: National Electrical Code) standards (Germany: DIN standards), construction rules and safety instructions for installation of the PV module.

### 2-1. CLIMATE CONDITIONS

Install the PV module within the following conditions:

- Ambient temperature:  $-20^{\circ}\text{C}$  to  $40^{\circ}\text{C}$  ( $-4$  to  $104^{\circ}\text{F}$ )
- Operating temperature:  $-20^{\circ}\text{C}$  to  $83^{\circ}\text{C}$  ( $-4$  to  $181^{\circ}\text{F}$ )
- Allowable pressure

<b>TD</b>	<b>AD</b>	<b>UD</b>	3600Pa
<b>TE</b>	<b>AE</b>	<b>UE</b>	(Snowfall) below 2000Pa (Wind) below 3000Pa

- Water resistance/damage: PV modules shall not be immersed in water and shall not be continually exposed to water from a sprinkler, fountain, etc.
- Corrosion warning: PV module shall not be installed in corrosive area like,
  - Salty area: area within 500 m from a body of salt water and/or area where salty wind hit directly, or
  - Sulfurous area: area near sulfurous volcano and sulfurous spring.

### 2-2. ORIENTATION

- Install the PV modules facing South (in Northern Hemisphere), or to the North (in Southern Hemisphere). Modules facing West or East generate a smaller amount of electricity than facing South (in Northern Hemisphere) or North (in Southern Hemisphere). Incorrect orientation will result in loss of power output.
- PV modules connected in series should be installed at the same orientation and angle. Different orientation or angles may cause loss of output power due to the different amount of sunlight exposed to each of the modules.
- Install the PV module as free as possible from shade. Shade causes loss of electrical output, even though the factory fitted bypass diode of the PV module will reduce such loss to some extent.

**ELECTRICAL SPECIFICATION  
ELEKTRISCHE DATEN  
SPÉCIFICATIONS ÉLECTRIQUES  
CARATTERISTICHE ELETTRICHE**

TYPE		MODEL MODELL MODÈLE MODELLO	Pmax	Voc	Isc	Vmp	Imp	*1 [A]	*2 [A]	MAXIMUM SYSTEM VOLTAGE MAXIMALE SYSTEMSPANNUNG TENSION MAXIMUM SYSTEME TENSIONE MASSIMA DI SISTEMA
50-cell	TD	PV-TD170MF5, PV-AD170MF5	170 W	29.9 V	7.83 A	23.7 V	7.19 A	15	12.5	1000V
		PV-TD175MF5, PV-AD175MF5	175 W	30.2 V	7.93 A	23.9 V	7.32 A	15	12.5	
		PV-TD180MF5, PV-AD180MF5	180 W	30.4 V	8.03 A	24.2 V	7.45 A	15	12.5	
		PV-TD185MF5, PV-AD185MF5	185 W	30.6 V	8.13 A	24.4 V	7.58 A	15	12.5	
		PV-TD190MF5, PV-AD190MF5	190 W	30.8 V	8.23 A	24.7 V	7.71 A	15	12.5	
	UD	PV-UD170MF5	170 W	29.9 V	7.83 A	23.7 V	7.19 A	15	12.5	600V
		PV-UD175MF5	175 W	30.2 V	7.93 A	23.9 V	7.32 A	15	12.5	
		PV-UD180MF5	180 W	30.4 V	8.03 A	24.2 V	7.45 A	15	12.5	
		PV-UD185MF5	185 W	30.6 V	8.13 A	24.4 V	7.58 A	15	12.5	
		PV-UD190MF5	190 W	30.8 V	8.23 A	24.7 V	7.71 A	15	12.5	
		PV-UD195MF5	195 W	31.0 V	8.33 A	24.9 V	7.84 A	15	12.5	
36-cell	TE	PV-TE115MF5N, PV-AE115MF5N	115 W	21.5 V	7.60 A	17.1 V	6.75 A	15	12.5	1000V
		PV-TE120MF5N, PV-AE120MF5N	120 W	21.6 V	7.75 A	17.2 V	6.99 A	15	12.5	
		PV-TE125MF5N, PV-AE125MF5N	125 W	21.8 V	7.90 A	17.3 V	7.23 A	15	12.5	
		PV-TE130MF5N, PV-AE130MF5N	130 W	21.9 V	8.05 A	17.4 V	7.47 A	15	12.5	
		PV-TE135MF5N, PV-AE135MF5N	135 W	22.0 V	8.20 A	17.5 V	7.72 A	15	12.5	
	UE	PV-UE115MF5N	115 W	21.5 V	7.60 A	17.1 V	6.75 A	15	12.5	600V
		PV-UE120MF5N	120 W	21.6 V	7.75 A	17.2 V	6.99 A	15	12.5	
		PV-UE125MF5N	125 W	21.8 V	7.90 A	17.3 V	7.23 A	15	12.5	
		PV-UE130MF5N	130 W	21.9 V	8.05 A	17.4 V	7.47 A	15	12.5	
		PV-UE135MF5N	135 W	22.0 V	8.20 A	17.5 V	7.72 A	15	12.5	
-		TOLERANCE TOLERANZ TOLÉRANCE TOLLERANZA	TD, AD, UD : *3 TE, UE: *4	*5	*5	-	-	-	-	-

Pmax, Voc, Isc, Vmp and Imp are values under Standard Test Condition (STC).  
STC Cell temperature: 25°C, Irradiance: AM1.5, 1000W/m<sup>2</sup>

Pmax, Voc, Isc, Vmp, Imp sind Werte gemäß STC (Standard-Prüfbedingungen)  
STC Die Zelletemperatur: 25°C, Bestrahlungsstärke: AM1,5, 1000W/m<sup>2</sup>

Pmax, Voc, Isc, Vmp, Imp sont des valeurs conformes aux conditions d'essais normalisées (STC).  
STC Température de la cellule : 25°C, Rayonnement : AM1,5, 1000W/m<sup>2</sup>

Pmax, Voc, Isc, Vmp e Imp sono riferiti alle Condizioni Standard di Test (STC - Standard Test Condition ).  
STC Temperatura della cella: 25°C, Irraggiamento: AM1.5, 1000W/m<sup>2</sup>

**Symbols definition  
Definition der Symbole  
Définition des symboles  
Legenda dei simboli**

Pmax	MAXIMUM POWER	HÖCHSTLEISTUNG	PUISSANCE MAXIMUM	POTENZA MASSIMA
Voc	OPEN CIRCUIT VOLTAGE	LEERLAUFSPANNUNG	TENSION CIRCUIT OUVERT	TENSIONE A CIRCUITO APERTO
Isc	SHORT CIRCUIT CURRENT	KURZSCHLUSSSTROM	COURANT COURT-CIRCUIT	TENSIONE DI CORTO CIRCUITO
Vmp	MAXIMUM POWER VOLTAGE	HÖCHSTLEISTUNGSSPANNUNG	TENSION PUISSANCE MAXIMUM	TENSIONE DI MASSIMA POTENZA
Imp	MAXIMUM POWER CURRENT	HÖCHSTLEISTUNGSSTROM	TENSION COURANT MAXIMUM	CORRENTE DI MASSIMA POTENZA
*1	SERIES FUSE RATING	BEMESSUNGSSTROM DER SERIENSICHERUNGEN	VALEUR NOMINALE FUSIBLE SÉRIE	CARATTERISTICHE FUSIBILE
*2	MINIMUM BYPASS DIODE RATING	MINDESTBEMESSUNGSWERT DER BYPASSDIODEN	VALEUR NOMINALE MINIMUM DIODE DÉRIVATION	CARATTERISTICHE MINIMALI DIODO DI BYPASS
*3	±3% OF NOMINAL VALUE (except for 170W model)	±3% DES NENNWERTS (außer 170W MODELL)	±3% VALEUR NOMINALE (excepté 170W MODÈLE)	±3% DEL VALORE NOMINALE (tranne 170W MODELLO)
*4	+10/-5% OF NOMINAL VALUE	+10 / -5% DES NENNWERTS	+10 / -5% VALEUR NOMINALE	+10/-5% DEL VALORE NOMINALE
*5	±10% OF NOMINAL VALUE	±10% DES NENNWERTS	±10% VALEUR NOMINALE	±10% DEL VALORE NOMINALE

## 2-3. MOUNTING

### ⚠ WARNING

- DO NOT install the PV module near an open flame or flammable materials.
- Use mounting framework that can withstand forces from wind pressure and snowfall pressure specific to your local climate.
- Use mounting framework and brackets that can withstand the environment where the PV modules are to be used. Select proper corrosion resistant materials and coatings.
- Use appropriate safeguards and components to attach the module when installing it on a location high on the building, or any other structure from which a fall of the module could cause death, personal injury or damage to property.
- Fasten the PV modules to the mounting framework firmly so that the modules will not be affected by wind and snow loads. The framework should meet relevant building standards. (Refer to DIN1055 in Germany)

### ⚠ CAUTION

- Install the PV module with enough space for air circulation behind the PV module to dissipate heat.
- DO NOT block frame drainage holes at each corner of module.

### 2-3-1. Mounting using bolt holes

Examples of mounting method:

- Use the 4 corner holes of the PV module to bolt to the mounting framework.
- When more strength is required, use all 6 holes including the center holes on two sides ( **TE** **AE** **UE** ).
- Use spring washers and flat washers to fasten the PV module.
- Install the PV module securely such as fastening the appropriate bolts with double nuts and locking washers.
- When the PV module is installed in such an area affected by wind and snowload, M8 bolt should be used for fastening instead of M6 bolt ( **TD** **AD** **UD** ).

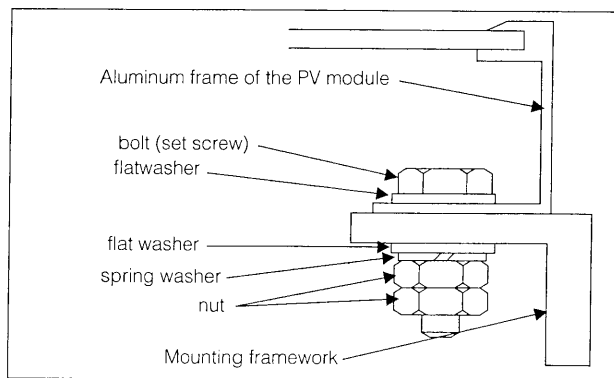

Fig. 1 Mounting to framework (Reference)

### 2-3-2. Mounting using "Clipping method"

"Clipping method" is the way to fix modules on the steady base profiles (rail structure etc.) with the "clipping" materials to catch the top of the frame, not to directly fix with bolts and nuts on the backside of module.

Mitsubishi Electric Corp doesn't specify or warrant any materials, e.g. base profile and clipping materials etc., related to clipping method.

### ⚠ WARNING

- DO NOT fix the module on only short side frames.

### ⚠ CAUTION

- Note that the drainage hole at each corner of module would not be blocked by the base profile if the profile were placed in parallel to the longer side frame.

- Base profile should be placed in perpendicular to the longer side frame of module in principle (see figure).
- Module shall be fixed at 4 places or more on the longer side frames.
- Refer to the figure and table for the allowable area to be fixed.
- Close the gap between the material and frame, and secure without loosening by M6 (1/4") or larger bolts (M8 (5/16")) for where the heavy snow load is expected.
- The hooked area should be more than 5mm in principle.
- Use the clipping material with sufficient strength and the shape that can withstand forces from wind pressure and snowfall pressure specific to local climate.
- Secure bolts with the appropriate torque not to change the shape of module.
- Add some measure to prevent the module from unfastening or sliding down so that the fallen module doesn't cause any damage for person and/or property.

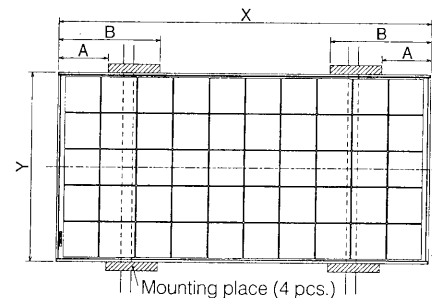

Table. Applicable models and allowable area to be fixed

No.	Type	Size [mm]		Allowable area [mm]	
		X	Y	A	B
1	50-cell <b>TD</b> <b>AD</b> <b>UD</b>	1658	834	280	430
2	36-cell <b>TE</b> <b>AE</b> <b>UE</b>	1495	674	260	370

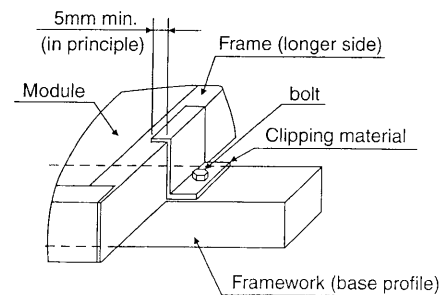

Fig. 2 Clipping method

## 2-4. GROUNDING

### ⚠ WARNING

- The grounding method should satisfy the Local Code and the National Electrical Code consistent with the specifications of PV system.
- Ground the module properly as appropriate for the conditions at the installation site.

Examples of proper grounding technique:

### 2-4-1. Method #1

- Secure the stainless steel screw (5/32" or M4) with 32 threads per inch to the grounding hole
- As shown in the figure 3, copper wire should be compressed by the screw head.
- Stainless steel washer with appropriate corrosion resistant coating should be inserted between copper wire and the frame to avoid galvanic corrosion.
- Proper cupped washer should be inserted between copper wire and screw head.

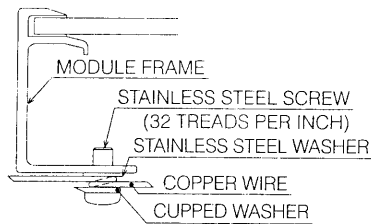

Fig. 3 Grounding method #1

### 2-4-2. Method #2

- If the mounting holes are not used to fix the module, one of them can be used for grounding.
- The appropriate device like "grounding lug" as shown in the figure 4 should be secured by stainless steel bolt, nut and washers.
- Toothed washer shall be inserted between the nut and the frame to break the anodized layer of frame.
- Stainless steel washer with appropriate corrosion resistant coating should be inserted between the grounding lug and frame.

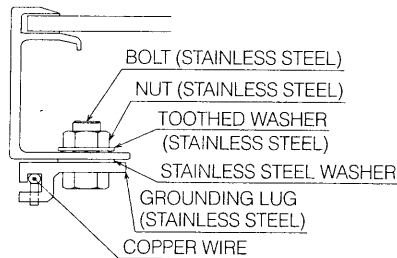
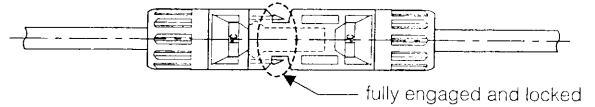

Fig. 4 Grounding method #2  
(use of "grounding lug")

## 2-5. WIRING

### ⚠ WARNING

- DO NOT short the positive and negative cables.
- Make sure connectors are fully engaged without a gap between the insulators and shall be locked. In case there is a gap, a fire and/or an electrical shock may occur.



### ⚠ CAUTION

- Connect the required number of PV modules to meet the voltage specification for equipment used in the PV system.
- Wire the output cable connectors so that they do not exert any force or pressure on the PV module's junction box. Attach the cable to the mounting framework using approved fasteners. The connectors should be placed behind the mounting framework so that the connectors can't be directly exposed to sunlight, wind and rain.
- To extend the cable, use proper commercial cables and connectors that can withstand outdoor use for long periods. Select the appropriate cable size according to its length to avoid voltage drop. Follow the cable manufacturer's instructions.

- The PV module has a pair of male and female waterproof connectors. For a series electrical connection, connect the positive (+) connector of the first PV module to the negative (-) connector of the following module.
- Connect the output cable to the other equipment in the system correctly.
- These modules employ UL Recognized connectors for the output wiring. Final output field wiring should be done with commercially available wiring products, such as Mitsubishi Electric Corporation Part Numbers "PV-DWMC" or equivalent kit with Multi-Contact connectors, PV-KST4II (Male), PV-KBT4II (Female) and with minimum 14 AWG cables rated for 90°C. These products will allow final system output wiring in accordance with the U.S. National Electrical Code, NFPA 70-2005. Please refer to Article 690 of the NEC for additional guidance.

## 3. MAINTENANCE

### ⚠ WARNING

- DO NOT touch live parts of wires, cables, connectors, or junction boxes. Be sure the circuit breaker is off, if it's applicable. Always use appropriate safety equipment (insulated tools, insulating gloves, etc.).
- Be sure to cover the front surface of the PV module with an opaque cloth or other material to block sunlight when working with the PV modules, because they generate high voltage when exposed to sunlight.

### ANNUAL INSPECTION

- Check if nuts, bolts of mounting framework are secure and not loose. Tighten all loose components.
- Check connections of cables, grounding cables and connectors.
- Check all electrical and mechanical connections for freedom from corrosion.
- Check the ground resistance of metal parts such as the module frames and the mounting framework.

 **MITSUBISHI ELECTRIC CORPORATION**

All Rights Reserved. Copyright©2007: MITSUBISHI ELECTRIC CORPORATION

Printed in Japan

0707874HF0201